

Product datasheet

Specifications



Easergy P3U 3CT 1Io ringlug 4VT 16DI 8DO 48-230V DI110V RS485

REL52016

Main

Range of product	PowerLogic P3
Product or component type	Protection relay
Relay application	Universal
product reference	P3U30-6AAA2BBAA
Mounting case size	30TE
power supply	48...230 V AC/DC
measuring inputs	: 1/5 A CT phase current 3 : 1/5 A CT residual current 1 : 100 V/110 V VT voltage 4
Number of sensors	0 temperature sensor(s) 0 arc sensor(s)
number of Digital Inputs (DI)	16
number of analogue inputs	0
number of Digital Outputs (DO)	1 watchdog 8
number of analogue outputs	0
type of temperature module connection	Copper cable external module Fiber optic cable external module
communication ports	USB port 1 front RS485 1 rear
communication protocols	IEC 60870-5-101 IEC 60870-5-103 DNP3 Modbus RTU DeviceNet SPAbus
Cybersecurity	Port hardening Password protection

Disclaimer: This documentation is not intended as a substitute for and is not to be used for determining suitability or reliability of these products for specific user applications

protection functions	<ul style="list-style-type: none"> Phase overcurrent 50/51 Directional phase overcurrent 67 Earth fault overcurrent 50N/51N Directional earth fault 67N Transient earth fault 67NI Capacitor bank unbalance 51C Broken conductor 46 I2/I1 Cold load pick-up Switch ON to fault (SOTF) Breaker failure 50BF Directional active underpower 37P Fault locator 21FL Recloser 79 Phase undercurrent 37 Excessive starting time, locked rotor 48/51LR Motor restart inhibition 66 Capacitor overvoltage 59C Negative sequence overcurrent 46 Overvoltage 59 Undervoltage 27 Positive sequence undervoltage 27P Earth fault overvoltage 59N Underfrequency 81/81N Rate of change of frequency 81R Synchro-check 25 Lockout relay 86 CT supervision 60 VT supervision 60 H2 detection 68H2 H5 detection 68H5 Negative sequence overcurrent 47 Programmable stages 99 Programmable curve
-----------------------------	--

Arc flash protection	No
-----------------------------	----

measurement functions	<ul style="list-style-type: none"> Current 3-phase Current zero sequence Current positive sequence Current negative sequence Current ratio of negative and positive Voltage phase to earth Voltage phase to phase Voltage zero sequence Voltage positive sequence Voltage negative sequence Voltage ratio of negative and positive Short circuit fault reactance Fault location current Earth fault reactance Frequency Active power RMS active power Reactive power RMS reactive power Apparent power RMS apparent power Active energy Reactive energy Cos ϕ Tan ϕ Power angle Power factor Voltage phasor diagram view Current phasor diagram view Current 2nd, 15th harmonics with THD Voltage 2nd, 15th harmonics with THD Voltage interruption Condition monitoring CB wear
------------------------------	---

control functions	<ul style="list-style-type: none"> Switchgear control and monitoring Programmable switchgear interlocking Local control on single-line diagram Local control with I/O keys Local/remote control 2 function keys Mobile application with Easergy SmartApp Web-server Programmable logic
--------------------------	---

controllable switchgear devices	4 controlled + 8 displayed
number of setting groups	4
monitoring functions	Trip circuit supervision 74 Circuit breaker monitoring Relay self-monitoring
logs and records	Event recording Disturbance recording Tripping context
Switchgear diagnosis type	CT/VT supervision ANSI code: 60 CT supervision Trip circuit supervision ANSI code: TCS
Connections - terminals	Screw removable (digital input/output) Ring lugs removable (current transformer) Pin removable (voltage transformer)

Complementary

Operating threshold	110...230 V AC/DC
Software name	EcoStruxure Power Device ESetup Easergy Pro
Web server	Embedded HTTP server
Display type	LCD 128 x 64 pixels with single line diagram
Number of key	2 customizable
Local signalling	4 LEDs 8 LEDs programmable
Standards	IEC
Height	169.5 mm
Width	170 mm
Depth	205 mm
Net weight	2.5 kg maximum

Environment

climatic withstand	Exposure to dry heat Bb tests conforming to EN/IEC 60068-2-2 Exposure to cold Ad tests conforming to EN/IEC 60068-2-1 Exposure to damp heat in service Db tests conforming to EN/IEC 60068-2-30 Exposure to damp heat in service Cab tests conforming to EN/IEC 60068-2-78
Mechanical robustness	Vibrations (level: class II) conforming to IEC 60255-21-1 Vibrations: Fc conforming to IEC 60068-2-6 Shocks (level: class II) conforming to IEC 60255-21-2 Shocks: Ea conforming to IEC 60068-2-27 Seismic tests method A (level: class II) conforming to IEC 60255-21-3 Bumps (level: class II) conforming to IEC 60255-21-2 Bumps: Ea conforming to IEC 60068-2-27
Electromagnetic compatibility	Emission tests conforming to IEC/EN 60255-26 ed. 3 Emission tests conforming to CISPR 11 Emission tests conforming to CISPR 22 EMC immunity conforming to IEC/EN 60255-26 ed. 3 EMC immunity conforming to EN/IEC 61000-4-18 EMC immunity level 4 conforming to EN/IEC 61000-4-2 EMC immunity level 3 conforming to EN/IEC 61000-4-3 EMC immunity level 4 conforming to EN/IEC 61000-4-4 EMC immunity level 3 conforming to EN/IEC 61000-4-5 EMC immunity level 3 conforming to EN/IEC 61000-4-6 EMC immunity conforming to EN/IEC 61000-4-8 EMC immunity level 5 conforming to EN/IEC 61000-4-9 EMC immunity conforming to EN/IEC 61000-4-29 EMC immunity conforming to EN/IEC 61000-4-11 EMC immunity conforming to EN/IEC 61000-4-17

Ambient air temperature for operation	-40...65 °C
Ambient air temperature for storage	-40...70 °C
IP degree of protection	IP54 conforming to IEC 60529
maximum operating altitude	2000 m
Protective treatment	Conformal coating
Relative humidity	0...95 %, without condensation

Packing Units

Unit Type of Package 1	PCE
Number of Units in Package 1	1
Package 1 Height	30.000 cm
Package 1 Width	29.900 cm
Package 1 Length	39.800 cm
Package 1 Weight	3.673 kg
Unit Type of Package 2	P12
Number of Units in Package 2	8
Package 2 Height	45.000 cm
Package 2 Width	80.000 cm
Package 2 Length	120.000 cm
Package 2 Weight	36.999 kg

Contractual warranty

Warranty (in months)	24
----------------------	----



Environmental Data

Schneider Electric aims to achieve Net Zero status by 2050 through supply chain partnerships, lower impact materials, and circularity via our ongoing “Use Better, Use Longer, Use Again” campaign to extend product lifetimes and recyclability.

[Environmental Data explained >](#)

[How we assess product sustainability >](#)



Environmental footprint

Total lifecycle Carbon footprint	727 kg CO2 eq.
Carbon footprint of the manufacturing phase [A1 to A3]	92 kg CO2 eq.
Carbon footprint of the distribution phase [A4]	4 kg CO2 eq.
Carbon footprint of the installation phase [A5]	0.1 kg CO2 eq.
Carbon footprint of the use phase [B2, B3, B4, B6]	624 kg CO2 eq.
Carbon footprint of the end-of-life phase [C1 to C4]	8 kg CO2 eq.
Environmental Disclosure	Product Environmental Profile

Use Better



Materials and Substances

Packaging made with recycled cardboard	Yes
Packaging without single use plastic	No
SCIP Number	7fd15df9-a702-4a28-ad01-afb36a7b785f
EU RoHS Directive	Compliant By Exemption
REACH Regulation	Reference contains Substances of Very High Concern above the threshold

Use Longer



Lifetime extension

Repair	No
--------	----

Use Again



Repack and remanufacture

Recyclability potential, in %	32
End of life manual availability	End of Life Information
Take-back	Nej
WEEE Label	 The product must be disposed on European Union markets following specific waste collection and never end up in rubbish bins

Connections and Schema

Functional View

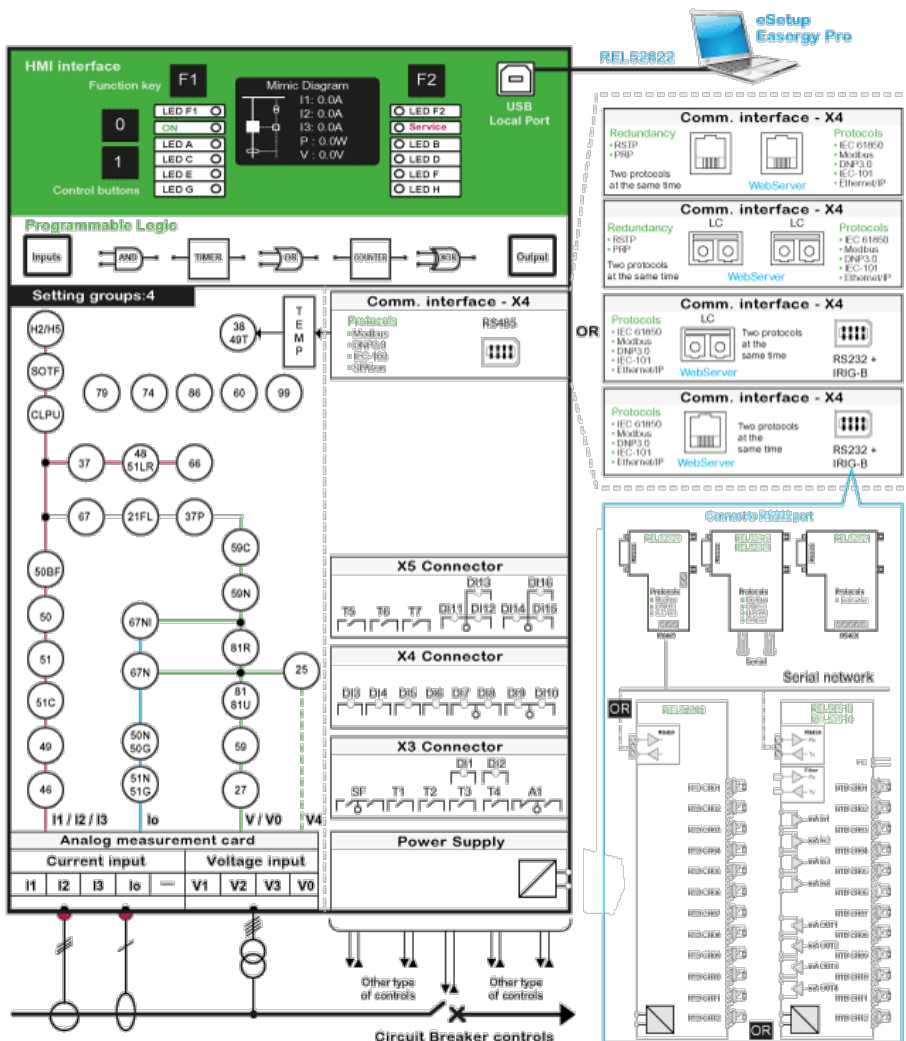

Dimensions Drawings

Base Unit Dimensions

mm
in.

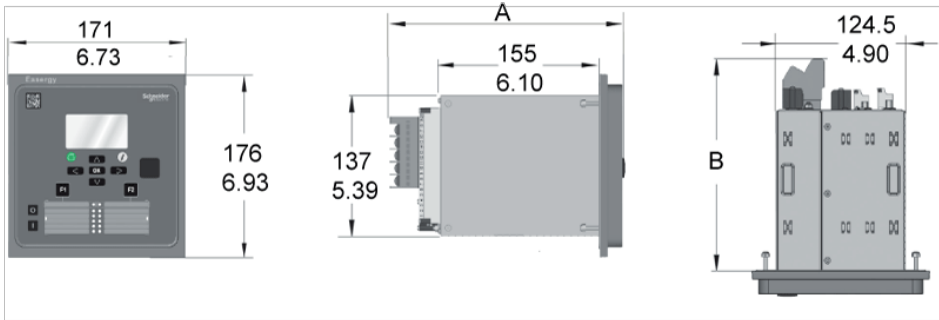

	A	B
With screw connector	214 mm/8.43"	192 mm/7.6"
With ring-lug connector	226 mm/8.90"	204 mm/8.0"