



by Schneider Electric

User Manual Smart-UPS™ SUA2200I-IND/SUA3000I-IND

Important Safety Information

SAVE THESE INSTRUCTIONS - This manual contains important instructions that should be followed during installation and maintenance of the Smart-UPS and batteries.

Read the instructions carefully and look at the equipment to become familiar with the device before trying to install, operate, service or maintain it. The following special messages may appear throughout this document or on the equipment to warn of potential hazards or to call attention to information that clarifies or simplifies a procedure.



The addition of this symbol either to a “Danger” or “Warning” safety label indicates that an electrical hazard exists which will result in personal injury if the instructions are not followed.



This is the safety alert symbol. It is used to alert you to potential personal injury hazards. Obey all safety messages that follow this symbol to avoid possible injury or death.

DANGER

DANGER indicates a hazardous situation which, if not avoided, will result in death or serious injury.

WARNING

WARNING indicates a hazardous situation which, if not avoided, could result in death or serious injury.

CAUTION

CAUTION indicates a hazardous situation which, if not avoided, could result in minor or moderate injury.

NOTICE

NOTICE is used to address practices not related to physical injury.

Safety and General Information

Inspect the package contents upon receipt. Notify the carrier and dealer if there is any damage.

Read the Safety Guide supplied with this unit before installing the UPS.

- Adhere to all national and local electrical codes.
- All wiring must be performed by a qualified electrician.
- Changes and modifications to this unit not expressly approved by APC could void the warranty.
- This UPS is for indoor use only.
- Do not operate this UPS in direct sunlight, in contact with fluids, or where there is excessive dust or high humidity.
- Do not operate the UPS near open windows or doors.
- Be sure the air vents on the UPS are not blocked. Allow adequate space for proper ventilation.
Note: Allow 20 cm clearance on both front and rear sides of the UPS.
- The equipment is heavy. Always practice safe lifting techniques adequate for the weight of the equipment.
- The battery typically lasts for two to three years. Environmental factors impact battery life. Elevated ambient temperatures, poor quality AC power, and frequent short duration discharges will shorten battery life.
- Connect the Smart-UPS power cable directly to a wall outlet. Do not use surge protectors or extension cords.
- Do not switch off the utility power to the UPS. Use the UPS on/off switch in the front panel to switch on/off the power to the connected loads.

Radio Frequency Warning

This is a Class A product. In a domestic environment this product may cause radio interference, in which case the user may be required to take corrective actions.

Product Handling Guidelines



<18 kg
<40 lb



18-32 kg
40-70 lb



32-55 kg
70-120 lb



>55 kg
>120 lb



Product Description

The APC by Schneider Electric Smart-UPS™ is a high performance uninterruptible power supply (UPS). The UPS helps to provide protection for electronic equipment from utility power blackouts, brownouts, sags, surges, small utility power fluctuations and large disturbances. The UPS also provides battery backup power for connected equipment until utility power returns to acceptable levels or the batteries are completely discharged.

This user manual is available on the APC by Schneider Electric web site, www.apc.com.

Package Contents

Inspect the contents upon receipt. Notify the carrier and dealer if the unit is damaged. Check the package contents:

- UPS
 - EPO connector
 - UPS literature kit containing:
 - Product Documentation
 - Safety Information
 - Warranty Information
- UPS literature kit additional contents:**
- Serial cable
 - USB communication cable
 - Input power cord
 - Output power cord

Installation

The UPS is heavy. Select a location sturdy enough to handle the weight.

NOTICE

RISK OF EQUIPMENT DAMAGE

- UPS must be used indoors only.
- The installation location should be sturdy to withstand the weight of the UPS.
- Do not operate UPS where there is a excessive dust or where the temperature or humidity are outside specified limits.

Failure to follow these instructions can result in equipment damage.

Connect Battery Module

CAUTION

RISK OF HYDROGEN SULPHIDE GAS AND EXCESSIVE SMOKE

- Do not dispose of the batteries in a fire. Do not short the terminals of the battery. The batteries may explode.
- Do not open or mutilate the batteries. Released electrolyte may be toxic and it is harmful to the skin and eyes.
- Replace battery at the end of its service life.
- Replace the battery immediately when the UPS indicates battery replacement is necessary.
- Replace batteries with the same number and type of batteries as originally install in the equipment.
- Replace the battery immediately when the UPS indicates a battery overtemperature condition, or UPS internal overtemperature, or when there is evidence of electrolyte leakage. Power off the UPS, unplug it from the AC input, and disconnect the batteries. Do not operate the UPS until the batteries have been replaced.

Failure to follow these instructions could result in equipment damage and minor or moderate injury.

Insert the battery connector into the battery jack and push firmly, twice. You will feel a snap as the connector partially engages the jack. Push firmly a second time. You will feel a second snap as the connector securely seats in the battery jack.

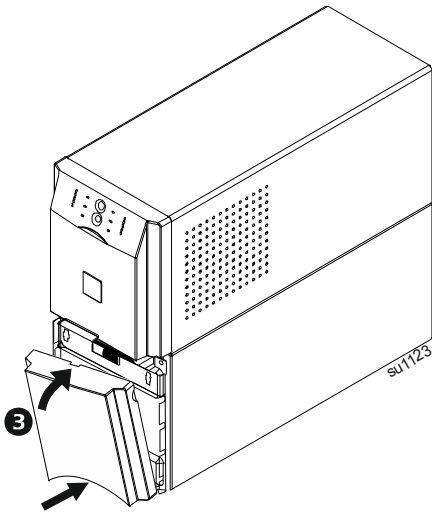
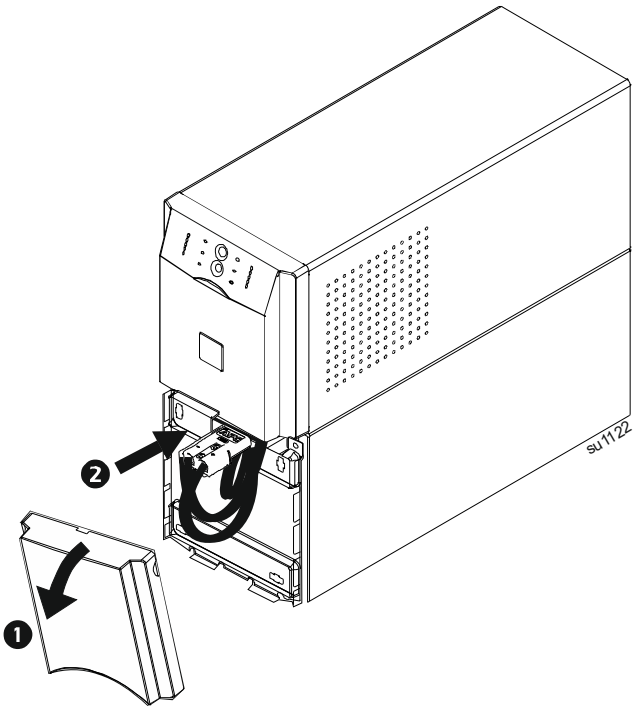

Start Up

Connect equipment and power to the UPS

CAUTION

HAZARD OF ELECTRIC SHOCK

- All electrical work must be performed by a qualified electrician.
- Turn off all power to this equipment before working on the equipment.
- Practice lockout/tagout procedures.
- Do not wear jewelry when working with electrical equipment.

Failure to follow these instructions can result in equipment damage and personal injury.

1. The UPS features a transient voltage surge-suppression (TVSS) screw located on the rear panel, for connecting the ground lead on surge suppression devices such as telephone and network line protectors.
Note: Prior to connecting the grounding cable, ensure that the UPS is NOT connected to utility or battery power.
2. Connect equipment to the UPS.
3. Add optional accessories to the SmartSlot.
4. Plug the UPS into a two-pole, three-wire, grounded receptacle only. Avoid using extension cords.
Note: The utility power cord is supplied in the UPS literature kit. Prior to connecting the utility power, connect the ground lead (optional) to the TVSS screw.
5. Turn on all connected equipment. To use the UPS as a master on/off switch, be sure all connected equipment is switched on.

Rear Panel Features

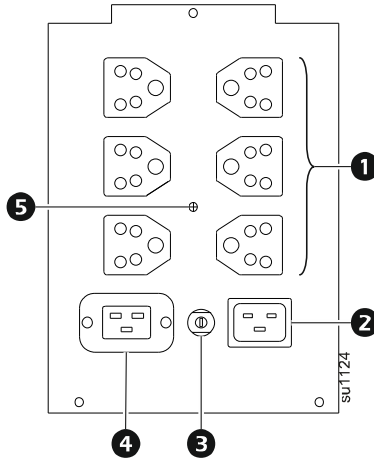

❶	Battery Backup Outlets	These outlets help provide battery backup power to the connected equipment for a limited period of time during power outages and voltage fluctuations. These outlets provide battery power to connected equipment only when the Smart-UPS is turned on.
❷	AC Inlet	Connect the UPS to utility power supply.
❸	Input Circuit Breaker	Press to reset in case the unit trips due to any overload condition.
❹	16 A Outlet	Single output.
❺	TVSS Screw	To connect the ground lead on surge suppression devices such as telephone and network line protectors.

Start the UPS

1. Press the POWER ON / SELF TEST button on the front panel to start the UPS.
 - a. The battery charges to 90% capacity during the first four hours of normal operation. Do not expect full battery run capability during this initial charge period.
 - b. Refer to the APC by Schneider Electric web site, www.apc.com for battery runtime.
2. For optimal computer system security, install PowerChute Smart-UPS monitoring software. See “PowerChute™ Personal Edition Software” on page 8.

PowerChute™ Personal Edition Software

Overview

PowerChute Personal Edition Software allows you to use your computer to access additional power protection and management features of the Smart-UPS.

Using PowerChute, you can:

- Preserve work in progress during a power outage by putting your computer into Hibernate mode. When the power returns, the computer will appear exactly as it did before the power outage.
- Configure the Smart-UPS management features, such as power-saving outlets, shutdown parameters, audible alarms, and more.
- Monitor and view the status of the Smart-UPS, including the estimated runtime, power consumption, power event history, and more.

Available features will vary by Smart-UPS model and operating system.

If you choose not to install PowerChute, the Smart-UPS will still provide backup power and power protection to connected equipment. However, you will only be able to configure a limited number of features using the display interface.

Compatibility

PowerChute is compatible with Windows operating systems only. For a detailed list of supported operating systems, go to APC by Schneider Electric web site, www.apc.com, select **Software & Firmware**.

For Mac operating systems, we recommend using the native shutdown application (within System Preferences) which recognizes your battery backup and allows you to configure shutdown of your system during power outages. To access this application, connect a USB cable from the Smart-UPS DATA PORT (POWERCHUTE PORT) to a USB port on your computer, and see the documentation provided with your computer.

Installation

To install PowerChute Personal Edition (PCPE) software, connect the supplied USB cable between the data port on the UPS and to a computer with access to the web.

On the computer, go to www.apc.com/tools/download. Select **Software Upgrades - PowerChute Personal Edition** in the **Filter by Software/Firmware** drop down menu. Select the appropriate operating system. Follow directions to download the software.

Emergency Power Off

NOTICE

RISK OF EQUIPMENT DAMAGE

Do not connect the EPO interface to any circuit other than a unused circuit.

Failure to follow these instructions can result in equipment damage.

The emergency power off (EPO) feature is user configurable. EPO provides immediate de-energizing of connected equipment from a remote location, without switching to battery operation.

1. Use the EPO connector supplied with the UPS.
2. Use a normally-open contact to connect the +24 terminal to the IN terminal.
3. Wire the four-pin connector to the EPO system.

EPO PORT (located on rear panel) EPO Connector

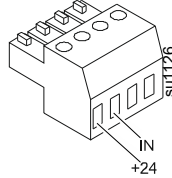
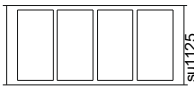





The EPO interface is a Safety Extra Low Voltage (SELV) circuit. Connect it only to other SELV circuits. The EPO interface monitors circuits that have no determined voltage potential. Such closure circuits may be provided by a switch or relay properly isolated from the utility. To avoid damage to the UPS, do not connect the EPO interface to any circuit other than a closure type circuit.

Use one of the following cable types to connect the UPS to the EPO switch.

- CL2: Class 2 cable for general use.
- CL2P: Plenum cable for use in ducts, plenums, and other spaces used for environmental air.
- CL2R: Riser cable for use in a vertical run in a floor-to-floor shaft.
- CLEX: Limited use cable for use in dwellings and for use in raceways.
- Use standard low-voltage cable in accordance with national and local regulations.





Display panel function buttons





Feature Button	Feature Title	Function
	POWER ON / SELF TEST	Press this button to turn on the UPS. Continue reading for additional capabilities.
	POWER OFF	Press this button to turn off the UPS.
	Self-Test	<p>Automatic: The UPS performs a self-test automatically when tuned on, and every two weeks thereafter (by default). During the self-test, the UPS briefly operates the connected equipment on battery.</p> <p>Manual: Press and hold the POWER ON / SELF TEST button for a few seconds to initiate the self-test.</p>
	Cold Start	When there is no utility power and the UPS is off, the cold start feature will switch the UPS and connected equipment onto battery power, (see “Troubleshooting” on page 15).

Configuration

UPS settings

Settings are adjusted through PowerChute software or optional Smart accessory cards.

Function	Factory Default	User Selectable Choices	Description
Automatic Self-Test	Every 14 days (336 hours)	Every 7 days (168 hours) On start up only No self-test	Set the interval at which the UPS will execute a self-test.
UPS ID	UPS_IDEN	Up to eight characters (alphanumeric)	Uniquely identify the UPS, (i.e. server name or location) for network management purposes.
Date of Last Battery Replacement	Manufacture Date	mm/dd/yy	Reset this date when you replace the battery module.
Minimum Capacity Before Return from Shutdown	0 percent	0% 50% 15% 60% 30% 75% 45% 90%	Specify the percentage to which batteries will be charged following a low battery shutdown before powering connected equipment.
Voltage Sensitivity The UPS detects and reacts to line voltage distortions by transferring to battery operation to protect the connected equipment.	High sensitivity 	Brightly illuminated: high sensitivity  Dimly illuminated: medium sensitivity  No illumination: low sensitivity 	Adjust by pressing the VOLTAGE SENSITIVITY  switch (rear panel). Use a pointed object, (such as a pen) to do so. Note: In situations of poor power quality, the UPS may frequently transfer to battery operation. If the connected equipment can operate normally under such conditions, reduce the sensitivity setting to conserve battery capacity and service life.

Function	Factory Default	User Selectable Choices	Description
Alarm Delay Control	Enable	Enable Mute Disable	Mute ongoing audible alarms or disable all audible alarms permanently.
Shutdown Delay	90 seconds	0 s 360 s 90 s 450 s 180 s 540 s 270 s 630 s	Set the interval between the time when the UPS receives a shutdown command and actual shutdown.
Low Battery Alert	2 minutes  PowerChute software interface provides automatic, unattended shutdown when approximately 2 minutes of battery operated run time remains.	<i>Brightly illuminated:</i> Low battery alert level of about 2 minutes  <i>Dimly illuminated:</i> Low battery alert level of about 5 minutes  <i>No illumination:</i> Low battery alert level is about 8 minutes 	The low battery alert beeps are continuous when 2 minutes of run time remain. To change the default interval setting, use a pointed object such as a pen to press the VOLTAGE SENSITIVITY  switch (rear panel), while pressing the POWER ON / SELF TEST button, (front display). Change the low battery alert interval setting to the time that the operating system or system software requires to shutdown.
Synchronized Turn-on Delay	0 seconds	0 s 240 s 60 s 300 s 120 s 360 s 180 s 420 s	Specify the time the UPS will wait after the return of utility power before start up, (to avoid branch circuit overload).
High Transfer Point	253 Vac	253 Vac 257 Vac 261 Vac 265 Vac	To avoid unnecessary use of the battery where utility voltage is chronically high, set the high transfer point higher if the connected equipment can tolerate this condition.

Function	Factory Default	User Selectable Choices	Description
Low Transfer Point	208 Vac	196 Vac 200 Vac 204 Vac 208 Vac	To avoid unnecessary use of the battery where utility voltage is chronically low, set the low transfer point lower if the connected equipment can tolerate this condition.
Output Voltage	230 Vac	220 Vac 240 Vac	Sets the output voltage of the UPS.



Replacing the Battery Module

This UPS has swappable battery modules.

Once the batteries are disconnected the connected equipment is not protected from power outages.

Refer to the appropriate replacement battery user manual for installation instructions.

Contact your dealer or go the APC by Schneider Electric web site, www.apc.com for information on replacement batteries.

 Pb	 Pb	<p>Be sure to deliver the spent battery(s) to a recycling facility or ship it to APC by Schneider Electric in the replacement battery packing material.</p>
---	---	---

Shipping

1. Shut down and disconnect any equipment attached to the UPS.
 2. Shut down the UPS, and disconnect the UPS from the utility power outlet.
 3. Unplug the battery connector, located on the rear panel.
- For further shipping instructions and to obtain appropriate packing materials, contact APC by Schneider Electric web site, www.apc.com.

Troubleshooting

Use this chart to solve minor UPS installation and operation problems. Refer to APC by Schneider Electric web site, www.apc.com with complex UPS problems.

Problem and/or Possible Cause	Solution
UPS will not turn on	
The battery is not connected properly.	Check that the battery connector is fully engaged.
POWER ON / SELF TEST button not pushed.	Press the POWER ON / SELF TEST button once to power-up the UPS and connected equipment.
The UPS is not connected to utility power supply.	Check that the power cable from the UPS to the utility power supply is securely connected at both ends.
Very low or no utility voltage.	Check the utility power supply to the UPS by plugging in a table lamp. If the light is very dim, have the utility voltage checked.
UPS will not turn off	
The UPS has detected an internal fault.	Do not attempt to use the UPS. Unplug the UPS and have it serviced immediately.
UPS beeps occasionally	
Normal UPS operation when running on battery.	None. The UPS is protecting the connected equipment. Press the POWER ON / SELF TEST button to silence the audible alarm.
UPS is not providing expected backup time	
The UPS battery(s) are weak due to a recent power outage or battery(s) are near the end of their service life.	Charge the battery(s). Batteries require recharging after extended outages. Batteries can wear faster when put into service often or when operated at elevated temperatures. If the battery(s) are near the end of their service life, consider replacing the battery(s) even if the <i>replace battery</i> is not yet illuminated.
All LEDs are illuminated and the UPS emits a constant beeping	
The UPS has detected an internal fault.	Do not attempt to use the UPS. Unplug the UPS and have it serviced immediately.

Problem and/or Possible Cause	Solution
Front panel LEDs flash sequentially	
The UPS has been shutdown remotely through software or an optional accessory card.	None. The UPS will restart automatically when utility power returns.
All LEDs are off and the UPS is plugged into a wall outlet	
The UPS is shut down or the battery is discharged from an extended outage.	None. The UPS will restart automatically when utility power is restored and the battery has a sufficient charge.
The Overload LED is illuminated and the UPS emits a sustained audible alarm tone	
The UPS is overloaded.	The connected equipment exceeds the specified “maximum load” as defined in Specifications on the APC by Schneider Electric web site, www.apc.com . The audible alarm remains on until the overload is removed. Disconnect nonessential equipment from the UPS to eliminate the overload condition. The UPS continues to supply power as long as it is online and the circuit breaker does not trip; the UPS will not provide power from batteries in the event of a utility voltage interruption.
The Replace Battery/Battery Disconnected LED is illuminated	
The <i>Replace Battery/Battery Disconnected</i> flashes and a short beep is emitted every two seconds to indicate the battery is disconnected.	Check that the battery connectors are fully engaged.
Weak battery.	Allow the battery to recharge for 24 hours and perform a self-test. If the problem persists after recharging, replace the battery.
Battery self-test not passed. <i>Replace Battery/Battery Disconnected</i> illuminates and the UPS emits short beeps for one minute. The UPS repeats the audible alarm every five hours.	Allow the battery to recharge for 24 hours. Perform the self-test procedure to confirm the replace battery condition. The audible alarm stops and the clears if the battery passes the self-test. Replace the battery if it does not pass the battery self-test. The connected equipment is unaffected.

Problem and/or Possible Cause	Solution
The input circuit breaker trips	
The connected equipment exceeds the specified “maximum load” as defined in <i>Specifications</i> on the APC by Schneider Electric web site, www.apc.com.	Unplug all nonessential equipment from the UPS. Reset the circuit breaker.
The AVR Boost or AVR Trim LEDs are illuminated	
The system is experiencing voltage out of the acceptable range.	Have a qualified service personnel check your facility for electrical problems. If the problem persists, contact the utility company for further assistance.
There is no utility power	
There is no utility power and the UPS is off.	Use the cold start feature to supply power to the connected equipment from the UPS battery(s). Press the POWER ON / SELF TEST button for one second and release. The UPS will beep briefly. Press and hold the POWER ON / SELF TEST button again for about three seconds. The unit will emit two beeps. Release the button during the second beep.
UPS operates on battery although line voltage exists	
The UPS input circuit breaker trips.	Unplug all nonessential equipment from the UPS. Reset the circuit breaker.
Your system is experiencing very high, low or distorted line voltage.	Move the UPS to a different outlet on a different circuit: Inexpensive fuel powered generators may distort the voltage. Test the input voltage with the utility voltage display, (see “Operation” on page 10). If acceptable to the connected equipment, reduce the UPS sensitivity.
Battery Charge and Load s flash simultaneously	
The UPS has shut down. The internal temperature of the UPS has exceeded the allowable threshold for operation.	Check that the room temperature is within the specified limits for operation. Check that the UPS is properly installed, allowing for adequate ventilation (see “Safety and General Information” on page 2 for more details). Allow the UPS to cool down. Restart the UPS. If the problem persists, contact APC by Schneider Electric.

Problem and/or Possible Cause	Solution
Diagnostic utility voltage	
All five LEDs are illuminated.	The line voltage is extremely high and should be checked by an electrician.
There is no illumination.	The line voltage is extremely high and should be checked by an electrician.
On Line	
There is no illumination.	The UPS is running on battery, or it must be turned on.
The LED is blinking.	The UPS is running an internal self-test.

Limited Factory Warranty

Schneider Electric IT Business India Private Ltd. (SEITBIPL), warrants its products to be free from defects in materials and workmanship for a period of two (2) years from the date of purchase. The SEITBIPL obligation under this warranty is limited to repairing or replacing, at its own sole option, any such defective products or parts thereof. Repair or replacement of a defective product or part thereof does not extend the original warranty period.

This warranty applies only to the original purchaser who must have properly registered the product within 10 days of purchase. Products may be registered online at warranty.apc.com or by mailing in the completed warranty registration card that is included with the documentation.

SEITBIPL shall not be liable under the warranty if its testing and examination disclose that the alleged defect in the product does not exist or was caused by end user's or any third person's misuse, negligence, improper installation, testing, operation or use of the product contrary to SEITBIPL's recommendations or specifications. Further, SEITBIPL shall not be liable for defects resulting from: 1) unauthorized attempts to repair or modify the product, 2) incorrect or inadequate electrical voltage or connection, 3) inappropriate on site operation conditions, 4) Acts of God, 5) exposure to the elements, 6) theft. In no event shall SEITBIPL have any liability under this warranty for any product where the serial number has been altered, defaced, or removed, 7) normal wear resulting from frequent use.

EXCEPT AS SET FORTH ABOVE, THERE ARE NO WARRANTIES, EXPRESS OR IMPLIED, BY OPERATION OF LAW OR OTHERWISE, APPLICABLE TO PRODUCTS SOLD, SERVICED OR FURNISHED UNDER THIS AGREEMENT OR IN CONNECTION HEREWITH.

SEITBIPL DISCLAIMS ALL IMPLIED WARRANTIES OF MERCHANTABILITY, SATISFACTION AND FITNESS FOR A PARTICULAR PURPOSE.

SEITBIPL EXPRESS WARRANTIES WILL NOT BE ENLARGED, DIMINISHED, OR AFFECTED BY AND NO OBLIGATION OR LIABILITY WILL ARISE OUT OF, SEITBIPL'S RENDERING OF TECHNICAL OR OTHER ADVICE OR SERVICE IN CONNECTION WITH THE PRODUCTS.

THE FOREGOING WARRANTIES AND REMEDIES ARE EXCLUSIVE AND IN LIEU OF ALL OTHER WARRANTIES AND REMEDIES. THE WARRANTIES SET FORTH ABOVE CONSTITUTE SEITBIPL'S SOLE LIABILITY AND PURCHASER'S EXCLUSIVE REMEDY FOR ANY BREACH OF SUCH WARRANTIES. SEITBIPL WARRANTIES EXTEND ONLY TO ORIGINAL PURCHASER AND ARE NOT EXTENDED TO ANY THIRD PARTIES.

IN NO EVENT SHALL SEITBIPL, ITS OFFICERS, DIRECTORS, AFFILIATES OR EMPLOYEES BE LIABLE FOR ANY FORM OF INDIRECT, SPECIAL, CONSEQUENTIAL OR PUNITIVE DAMAGES, ARISING OUT OF THE USE, SERVICE OR INSTALLATION OF THE PRODUCTS, WHETHER SUCH DAMAGES ARISE IN CONTRACT OR TORT, IRRESPECTIVE OF FAULT, NEGLIGENCE OR STRICT LIABILITY OR WHETHER SEITBIPL HAS BEEN ADVISED IN ADVANCE OF THE POSSIBILITY OF SUCH DAMAGES. SPECIFICALLY, SEITBIPL IS NOT LIABLE FOR ANY COSTS, SUCH AS LOST PROFITS OR REVENUE, WHETHER DIRECT OR INDIRECT, LOSS OF EQUIPMENT, LOSS OF USE OF EQUIPMENT, LOSS OF SOFTWARE, LOSS OF DATA, COSTS OF SUBSTITUANTS, CLAIMS BY THIRD PARTIES, OR OTHERWISE.

To obtain service under warranty you must call customer support. Customers with warranty claims issues may access the SEITBIPL worldwide customer support network through the SEITBIPL Web site: support.apc.com. Select your country from the country selection drop down menu. Open the Support tab at the top of the web page to obtain information for customer support in your region. Refer to the product user manual for more information on how to contact customer support.

Service

If the unit requires service, do not return it to the dealer. Follow these steps:

1. Review the *Troubleshooting* section of the manual to eliminate common problems.
2. If the problem persists, contact APC by Schneider Electric Customer Support.
 - a. Note the model number and serial number and the date of purchase. The model and serial numbers are located on the rear panel of the unit and are available through the LCD display on select models.
 - b. Call APC by Schneider Electric Customer Support and a technician will attempt to solve the problem over the phone. If this is not possible, the technician will issue a Service Request Number.
 - c. If the unit is under warranty, the repairs are free.

An Authorized Service Representative will visit your location and try to resolve the issue.

APC by Schneider Electric Customer Support India

Internet	http://www.apc.com/support
Toll Free	18001030011/18004194272
E-mail	indiainfo@schneider-electric.com